

Kemp Sails

Fully Battened Mainsails

Over the past 10 years or so, fully-battened mainsails have become ever more popular. In fact many sailors now automatically assume they're the best choice - but are they?

The pros...

Their popularity is not without good reason. Matched with lazyjacks and the right batten hardware, they can be easier to handle, stacking neatly on top of the boom instead of blowing all over the deck when you lower the halyard to put the sail away or tuck in a reef. Because the battens tend to hold the sail in shape, it flogs less, which makes for quieter and more relaxing sailing. The reduction in flogging also puts less strain on the rig, and helps the cloth last longer.

And what about performance? Fully-battened sails are often considered to be more efficient because of their use, among others, on racing dinghies, America's Cup yachts and high-speed multihulls. But none of these have a permanent backstay - and it's usually the backstay that limits the amount of roach you can build into the sail of a typical modern cruiser or cruiser/racer.

So you probably won't gain much area with a fully-battened main.

Nonetheless, it does tend to generate more lift - which, in turn, can lead to more speed and less heel upwind. In light airs, too, the shape built in by the battens gives these sails an edge when others are hanging limp. What's more, they're often closer-winded by virtue of being cut slightly flatter. Combined with their flog-resistance, this makes them especially useful for motor-sailing: you can bring the traveller to windward, haul the boom into the middle, and the sail will continue to fill until you're almost head-to-wind.

The cons

But it's not all good news. Perhaps the most obvious drawback is cost - fully-battened sails are inevitably more expensive. And the 'locked-in' shape also has a down-side: because of their ability to keep driving at very fine angles of attack, they're more difficult to de-power - so you'll find it harder to slow down or stop in a man-overboard situation, or when picking up moorings. It's no good approaching on a reach, easing the sheet and waiting for the boat to come to a halt, because it probably won't! You'll get used to it, but you have adopted a different style of sailing.

Chafe is something else to bear in mind. Especially on boats with angled spreaders - or swept-back rigging, like many multihulls - the battens are going to rub. The answer is anti-chafe patches, but we can't put them on when building the sail because we won't know exactly where it's going to come into contact with the rigging. That's why we need you to mark the 'trouble spots' and let us have the sail back at the end of the season.

Finally, racing sailors may find fully-battened mains less 'tweaky' than conventional, soft-batten types. Once again, it's down to the battens holding the sail in shape, which makes it slightly less responsive to some of the controls, especially the outhaul.

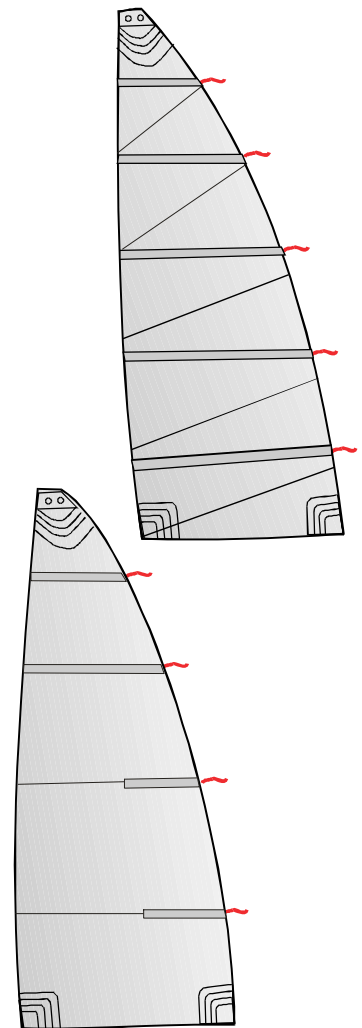

and a compromise....

As you can see, the arguments cut both ways. Usually, either a fully-battened or conventional sail will prove most suitable for you and your boat - but there's a third option. A sail with two full-length battens at the top and two or three shorter ones lower down offers many of the fully-battened sail's benefits, without the problems of chafe and the battens forming 'S' bends around the rigging. As ever, the decision-making process starts with a discussion - so come and talk things through with us.

What makes a Kemp sail different?

Being more costly and complex to build than conventional mains, fully-battened sails provide ample scope for sailmakers to cut corners. For example, you may find some quotations showing only four battens on boats up to around 35ft. At Kemp, we use a minimum of five. This way, the high compression loads on the luff - a feature of full-length battens - are more evenly distributed, giving you smoother running cars. Since one of the major benefits of fully-battened sails is their ease of handling, it's pointless to skimp in such a crucial area. Of course, the larger the boat (and the bigger the roach) the more battens we use. Another important feature we always incorporate - even in the Coastal sails - is a cunningham hole, because cunningham tension is essential in fresher winds to move the draft forward and open the leech.

Just as important is the right choice of batten end-fittings and mast sliders. That's why we ask you for details of your mast, including its section and a profile of the aft edge; only then can we select the hardware which will ensure the best performance and lowest friction. Here are two systems we usually recommend:

Rutgerson. The standard choice on smaller boats, with an upper size limit of 34/35ft. Rutgerson's roller cars have small wheels which roll up and down the aft face of the mast, either side of the luff groove - a simple, economical and well proven solution. Battens are inserted and adjusted at the leech, with the same Velcro-fastening system we use on our conventional mainsails.

Sailman. On larger boats - or for optimum friction-free operation further up or down the size range - we recommend Bainbridge's Sailman 4000 or 5000. The 4000's mast slider uses a slug inside the luff groove with wear pads on the outside; the battens are held at the luff in a captive box and adjusted with a Velcro tensioner at the leech. On larger sails, though, the leech is captive, and you tension the battens using a screw adjuster on the batten box at the luff.

Moving up the size range again, we come to the Sailman 5000, which features an external track bolted to the mast. This ensures a more precise fit between the track and cars for lower friction - essential with the high luff compression loads produced by full-length battens in large sails.

Other systems On some mast sections, neither the Rutgerson or Sailman will fit - so we use others, such as the SDA. But if you want the ultimate in low-friction running and don't mind spending a little more, your choice widens to include the Frederiksen and Harken ball-bearing systems. Without ball bearings, you'll generally have to go up to the mast to help the sail right down on to the boom. Introduce a ball race, though, and the sail's weight should bring it all the way down.

We can't over-emphasise the importance of selecting the correct fittings and mast sliders with full-length battens. Inappropriate hardware can make hoisting, reefing and lowering very hard work - but getting everything to run smoothly doesn't necessarily involve great expense. It's largely a matter of ensuring all the elements (batten end-fittings, mast sliders and mast section) are compatible. Since the whole idea of a fully-battened mainsail is to make life easier, we believe it's worth taking a little extra time and trouble to get it right.



Rutgerson roller car



Sailman batten car



Turn adjuster clockwise on the Sailman batten box to tension batten

**Kemp
Sails**

Kemp Sails Ltd., The Sail Loft, 2 Sandford Lane Industrial Estate, Wareham, Dorset BH20 4DY
Tel: 01929 554308 Fax: 01929 554350 email: info@kempsails.com www.kempsails.com